

FLC 40/80, FMC 40/80, FHC 40/80, FCW 80-1

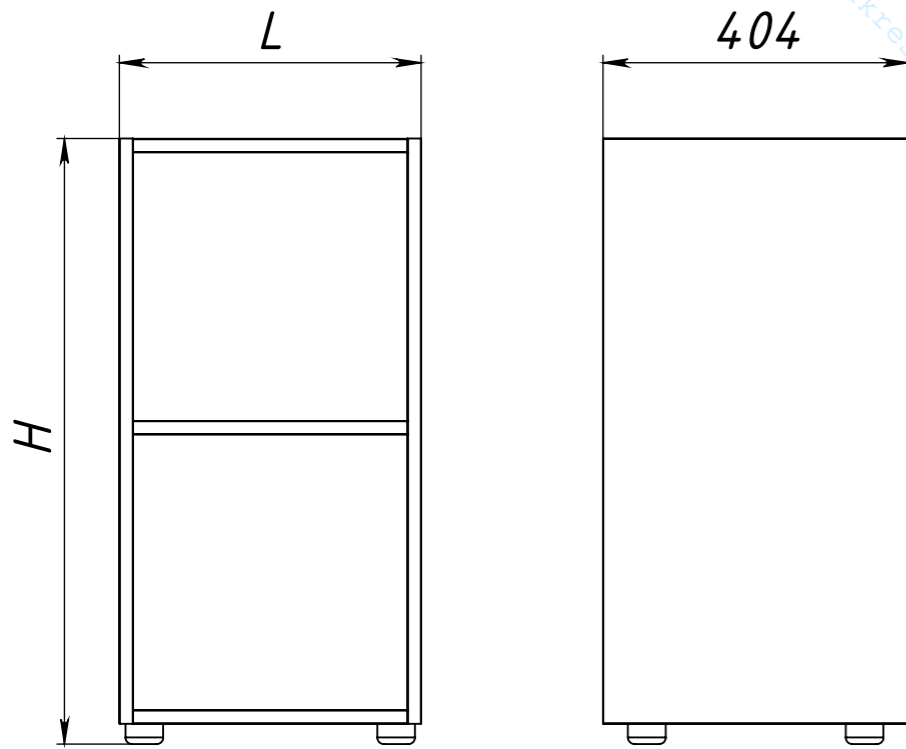

	L	H
FLC 40	399	801
FLC 80	798	801
FMC 40	399	1197
FMC 80	798	1197
FHC 40	399	1965
FHC 80	798	1965
FCW 80-1	798	1965

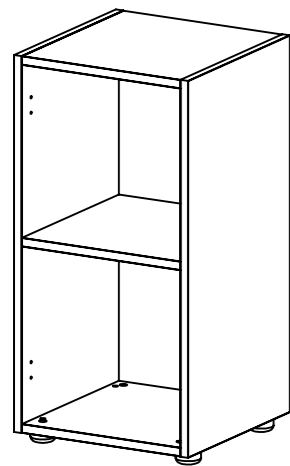

FLC 40

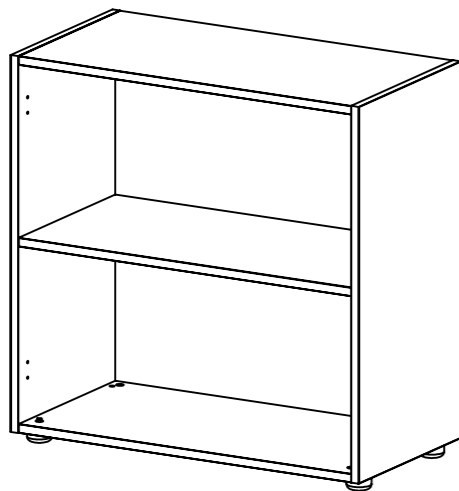

FLC 80

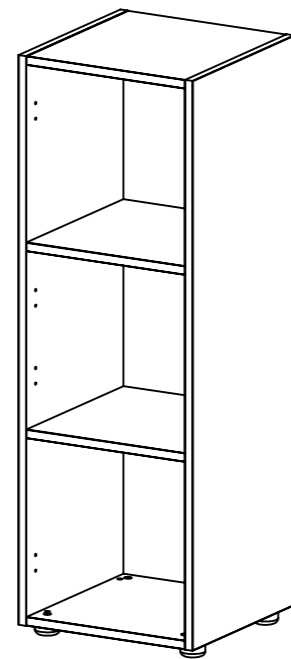

FMC 40

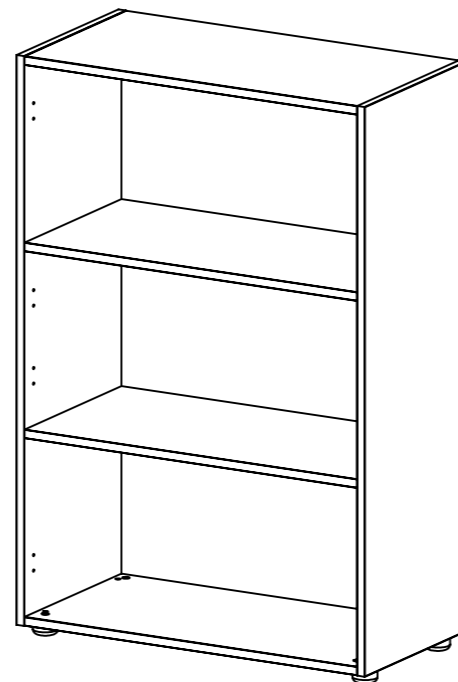

FMC 80

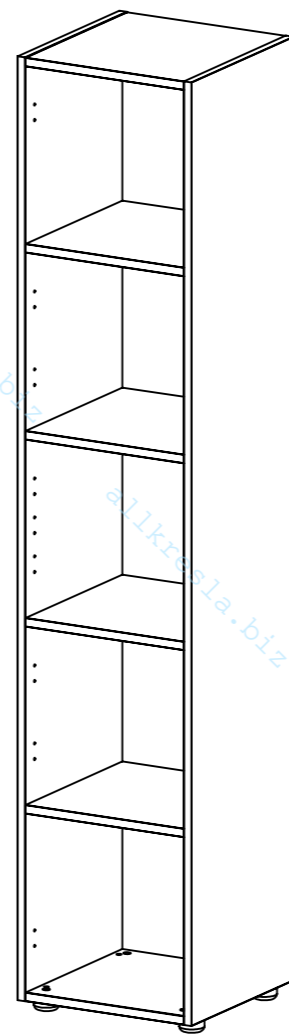

FHC 40

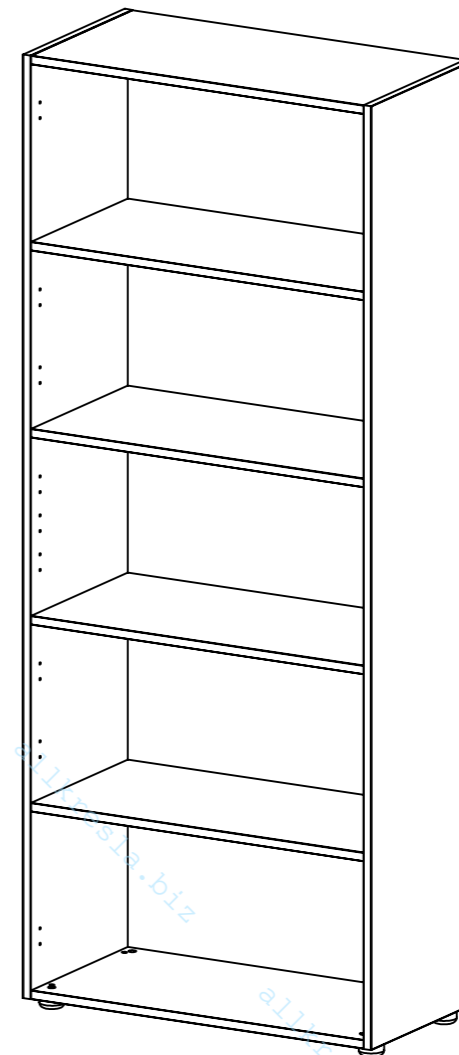

FHC 80

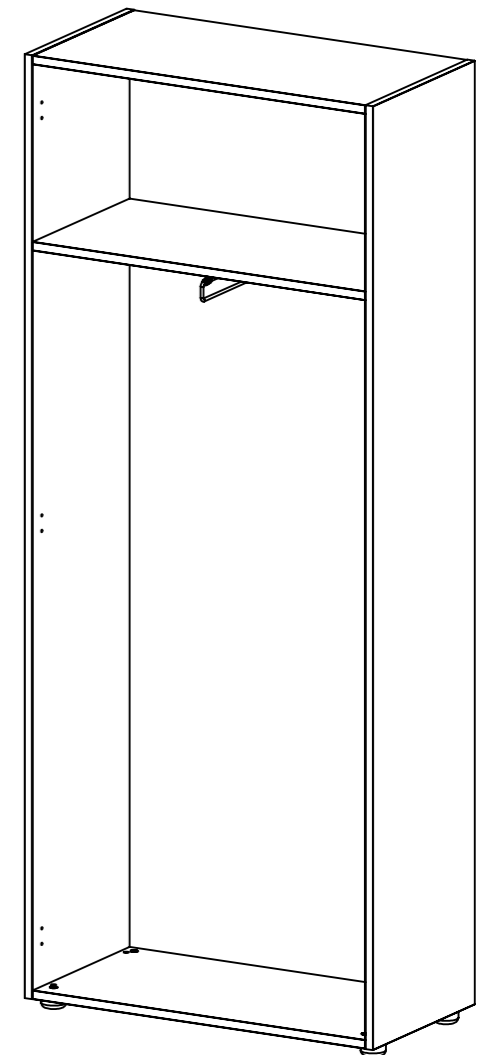

FCW 80-1

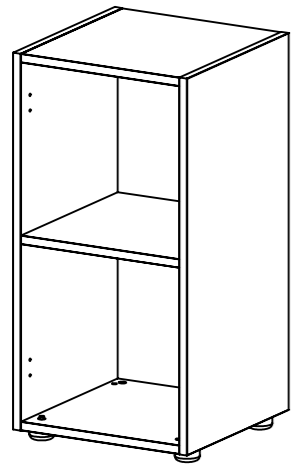

FLC 40

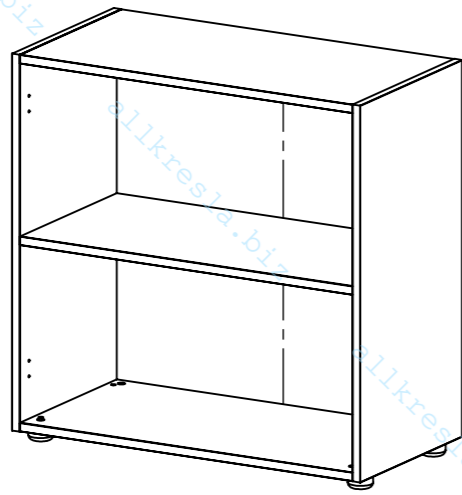

FLC 80

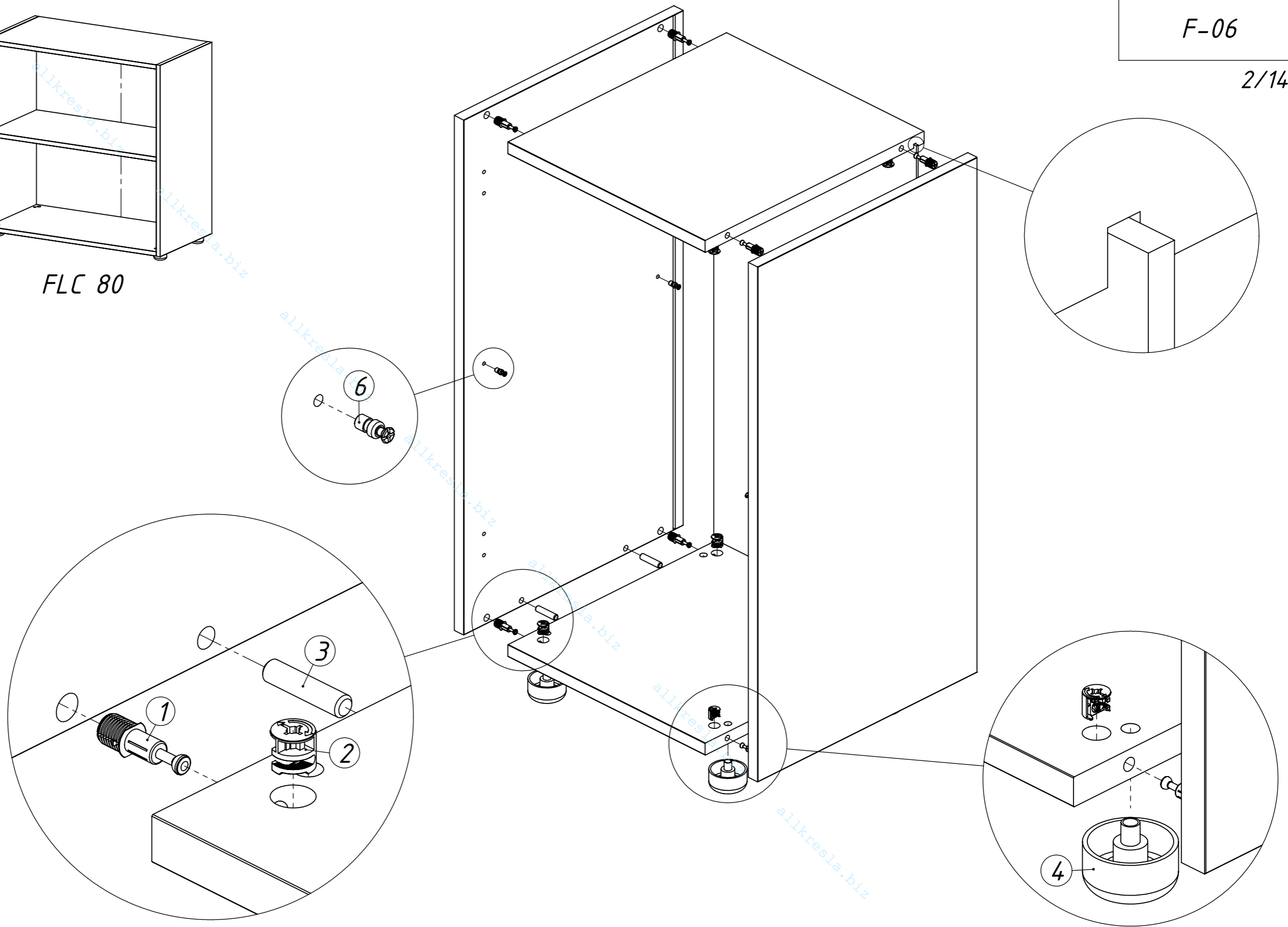

1	2	3	4	5	6	7	8	9	10	11	12
x8	x8	x4	x4	x4	x4	x6	3,5x16 x2	x2	x8	x4	x8

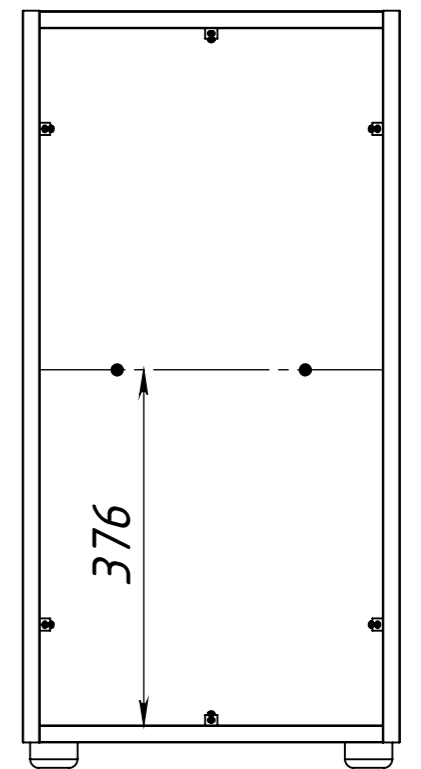
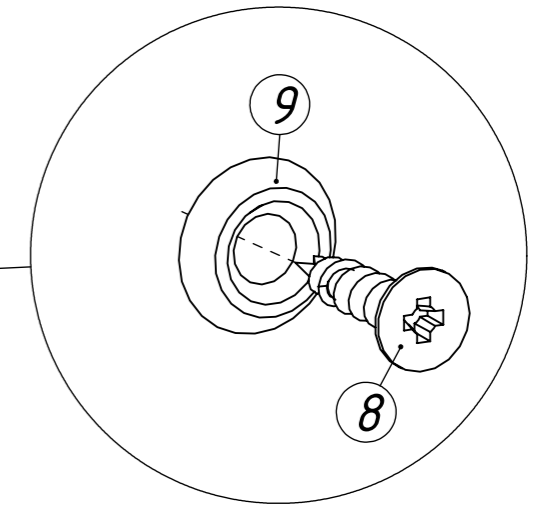
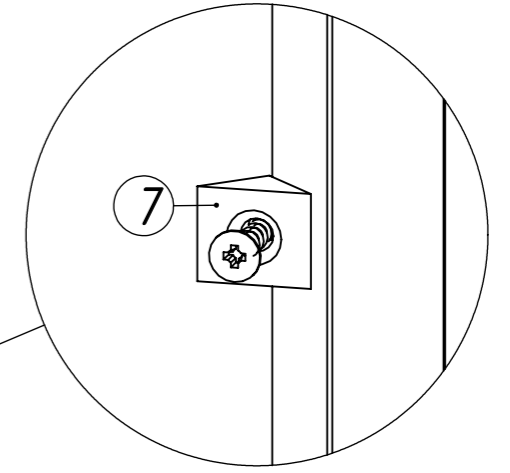
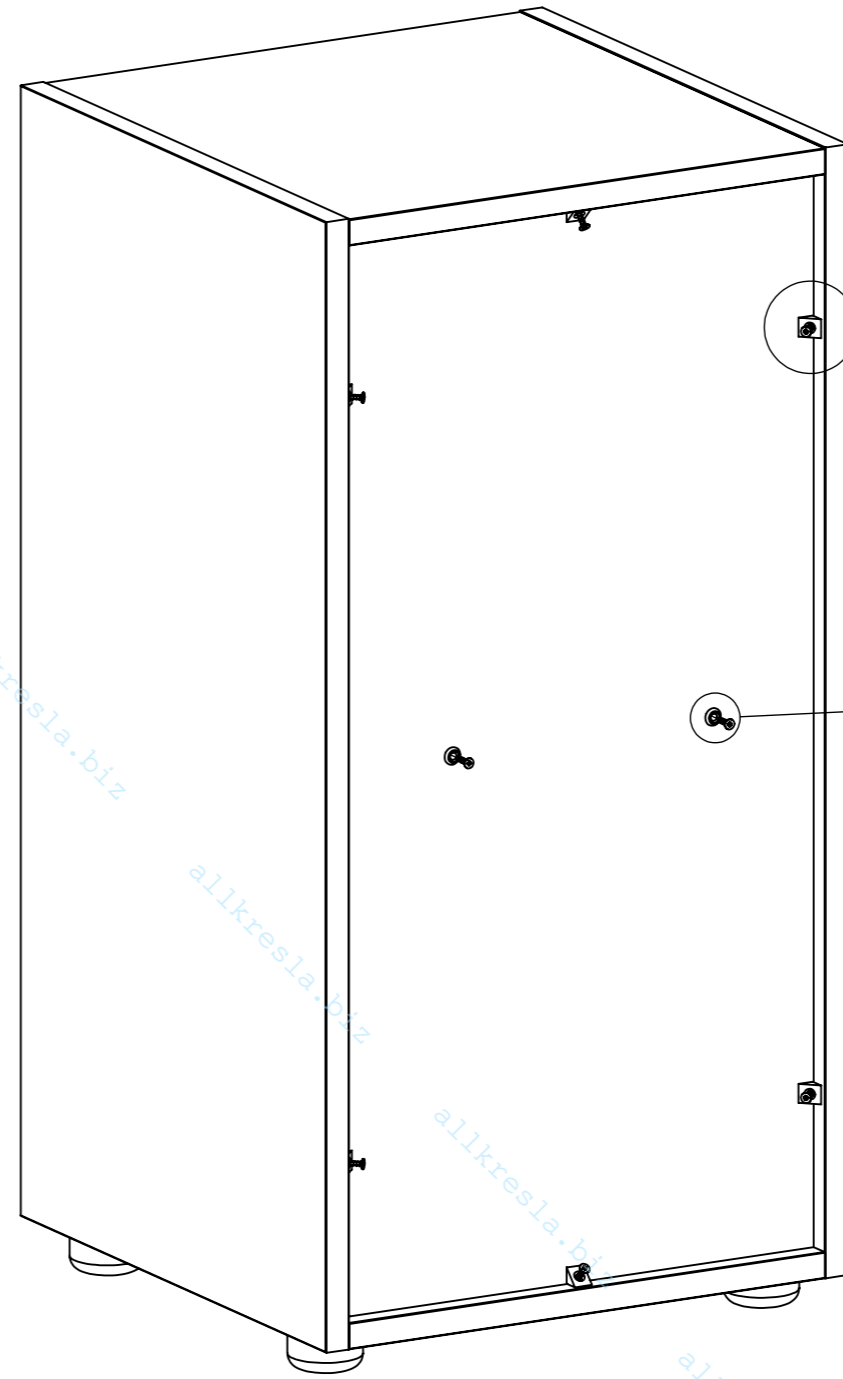
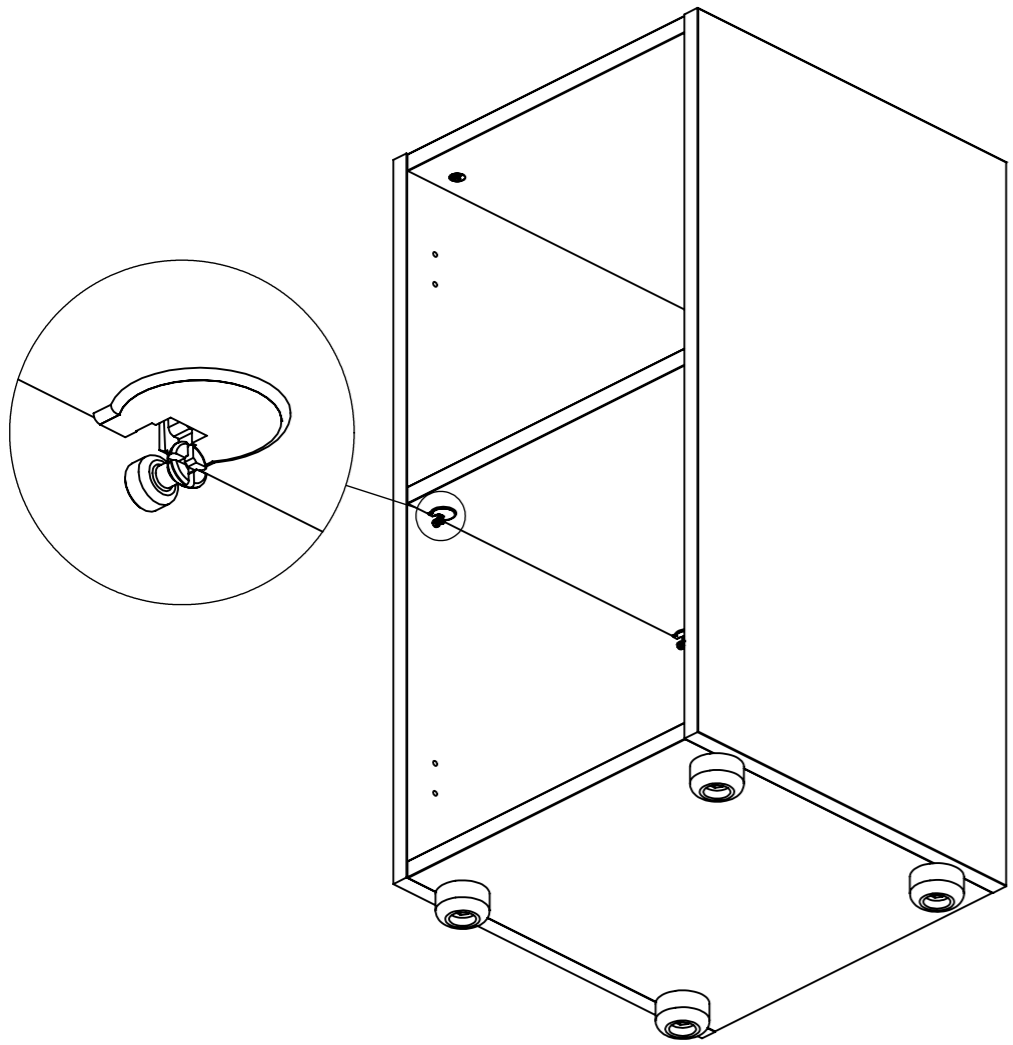
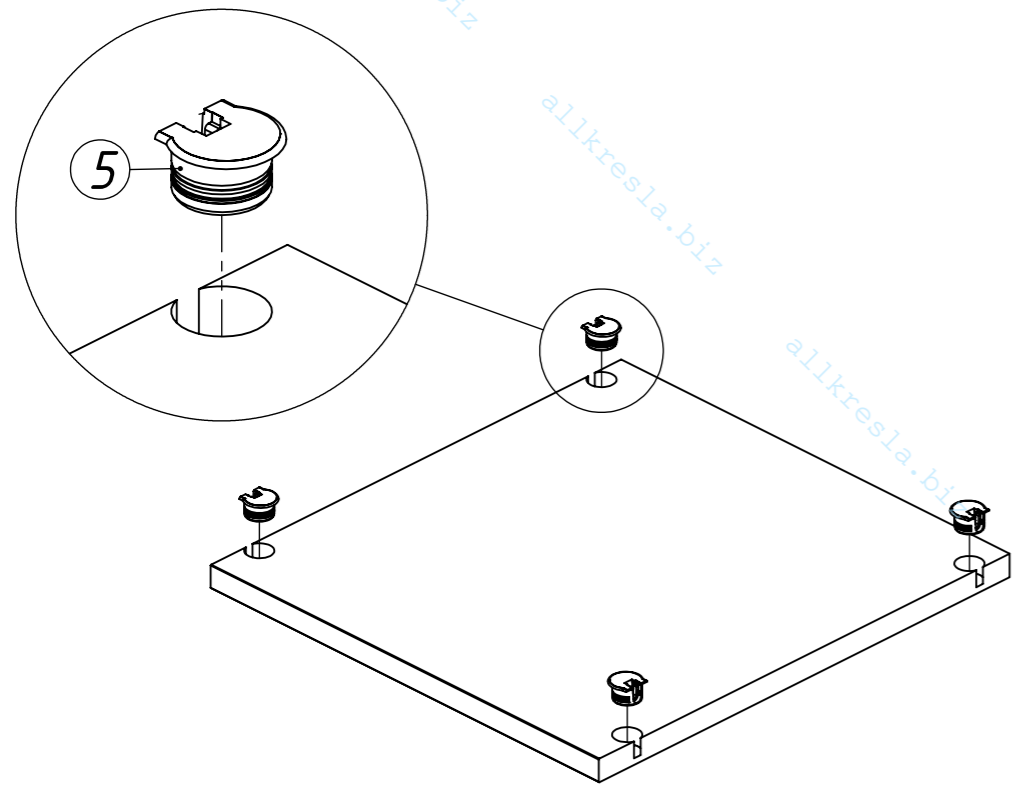

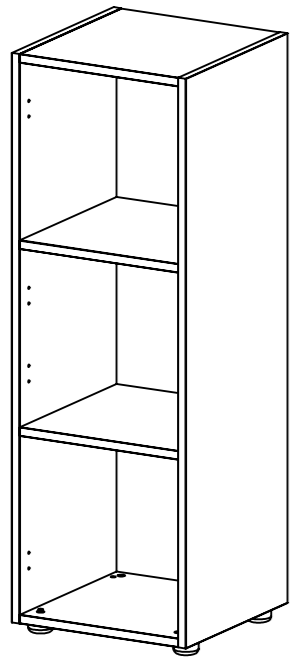



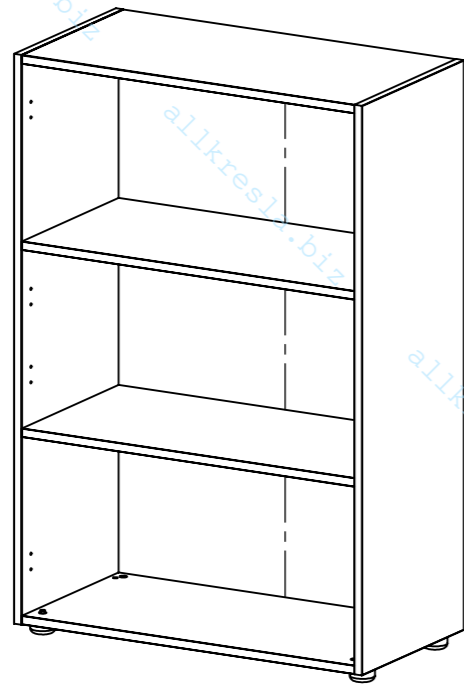

FMC 40

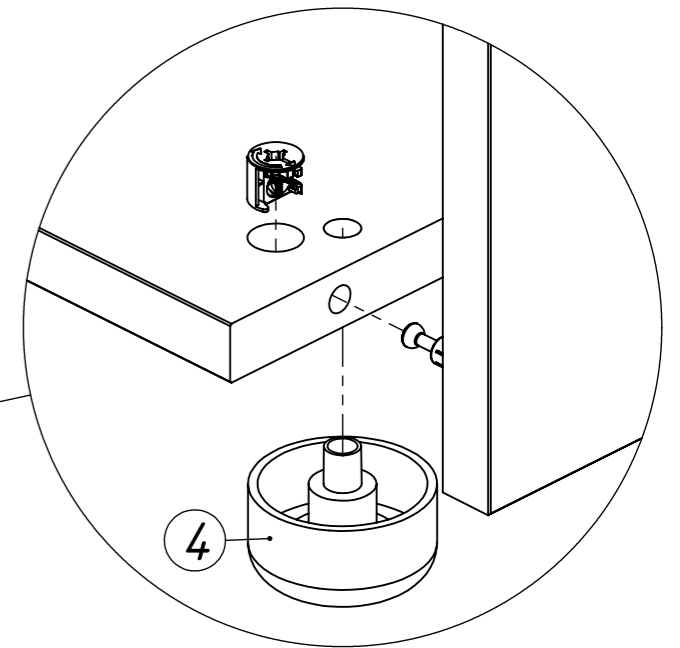
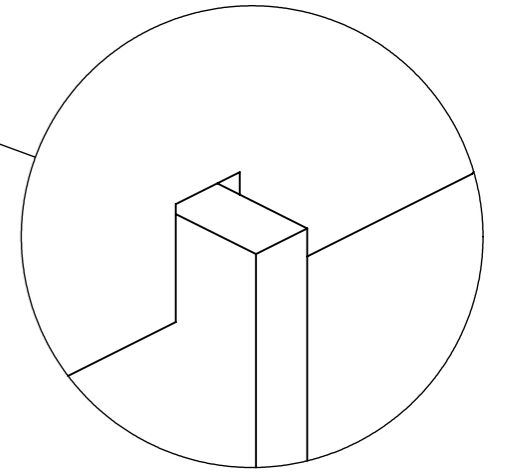
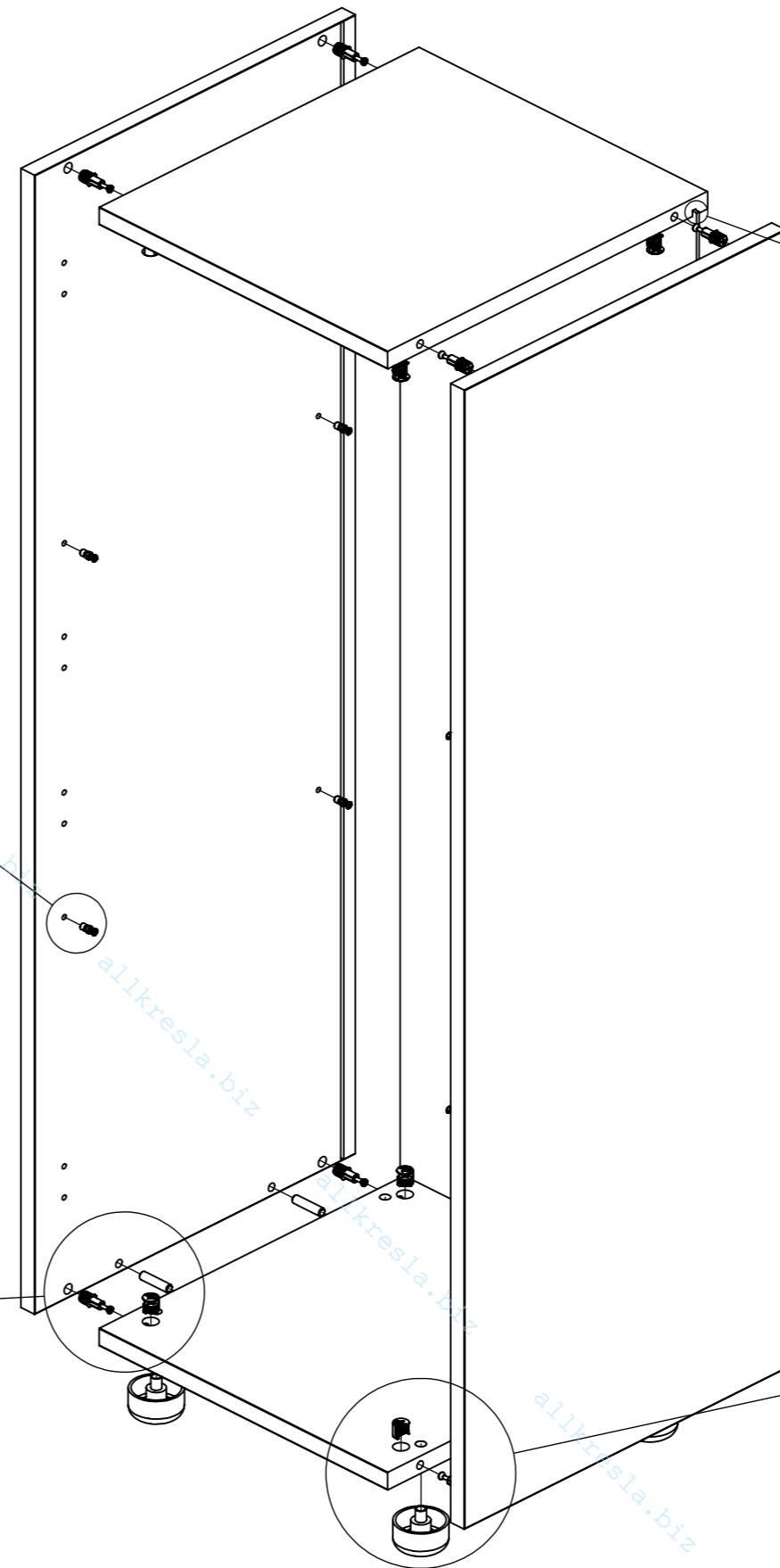
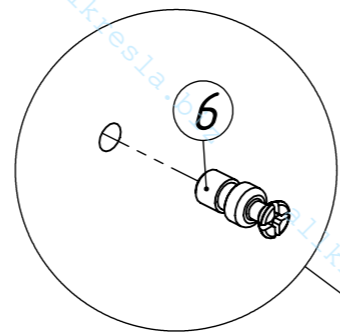
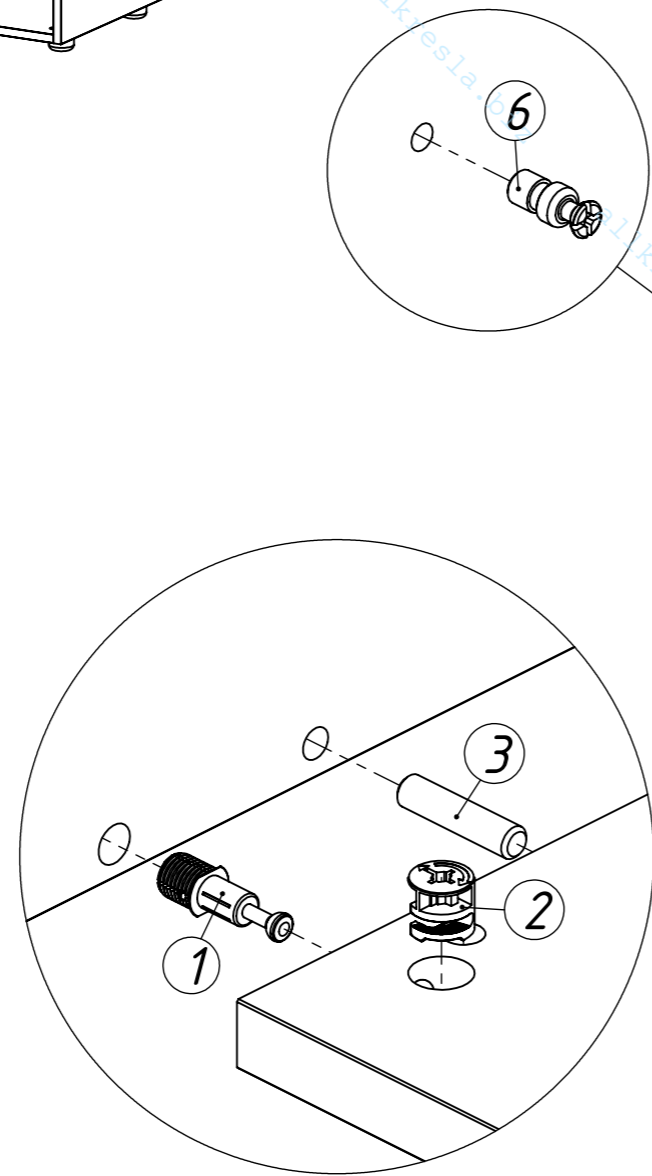

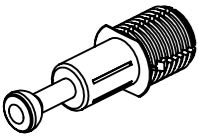
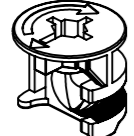
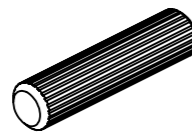
FMC 80

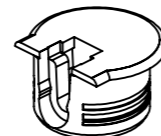
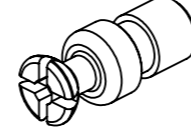
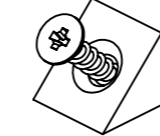
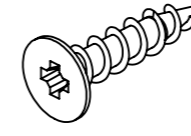
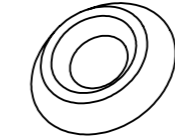

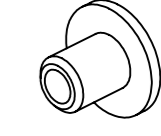
<p>1</p>  <p>x8</p>	<p>2</p>  <p>x8</p>	<p>3</p>  <p>x4</p>	<p>4</p>  <p>x4</p>	<p>5</p>  <p>x8</p>	<p>6</p>  <p>x8</p>	<p>7</p>  <p>x8</p>	<p>8</p>  <p>3,5x16 x4</p>	<p>9</p>  <p>x4</p>	<p>10</p>  <p>x8</p>	<p>11</p>  <p>x4</p>	<p>12</p>  <p>x16</p>
---	--	--	--	--	--	--	---	--	---	---	--

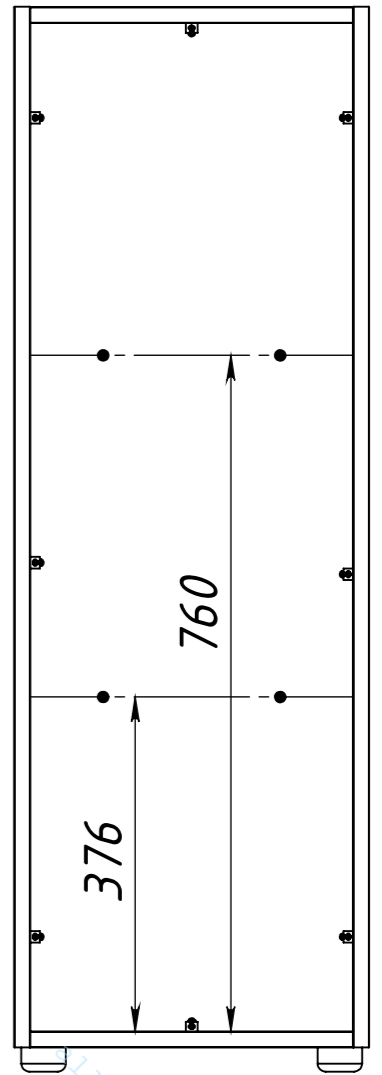
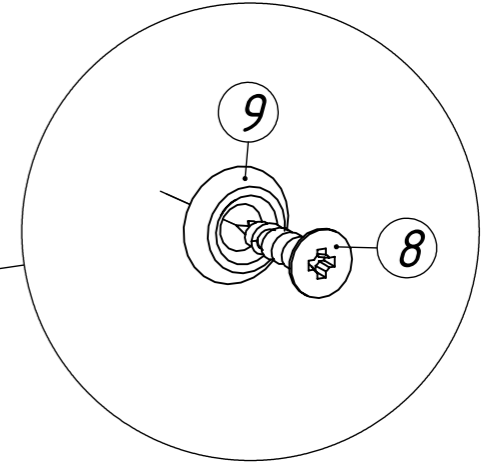
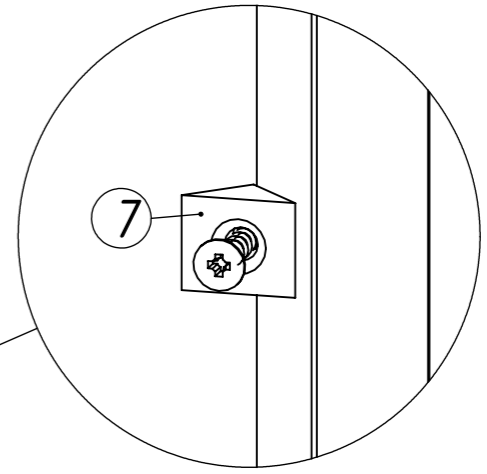
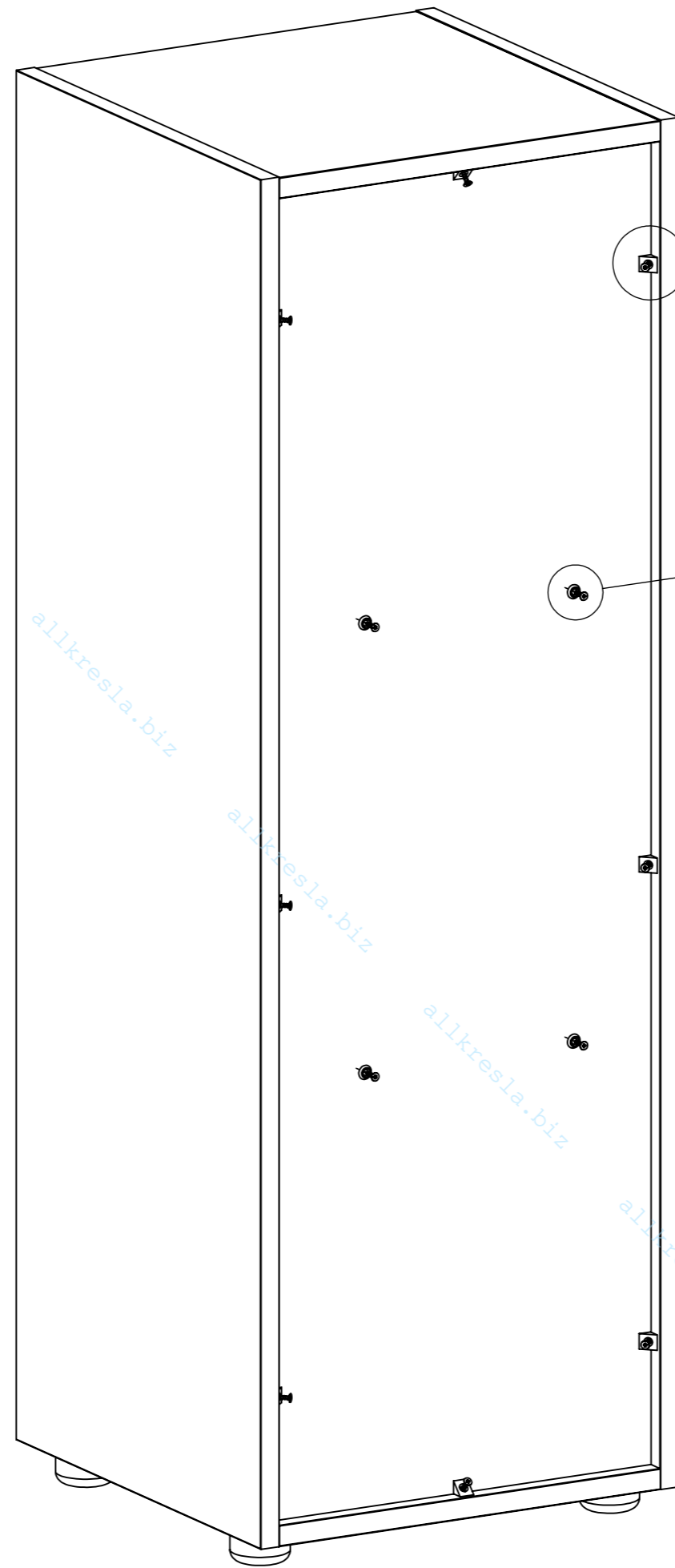
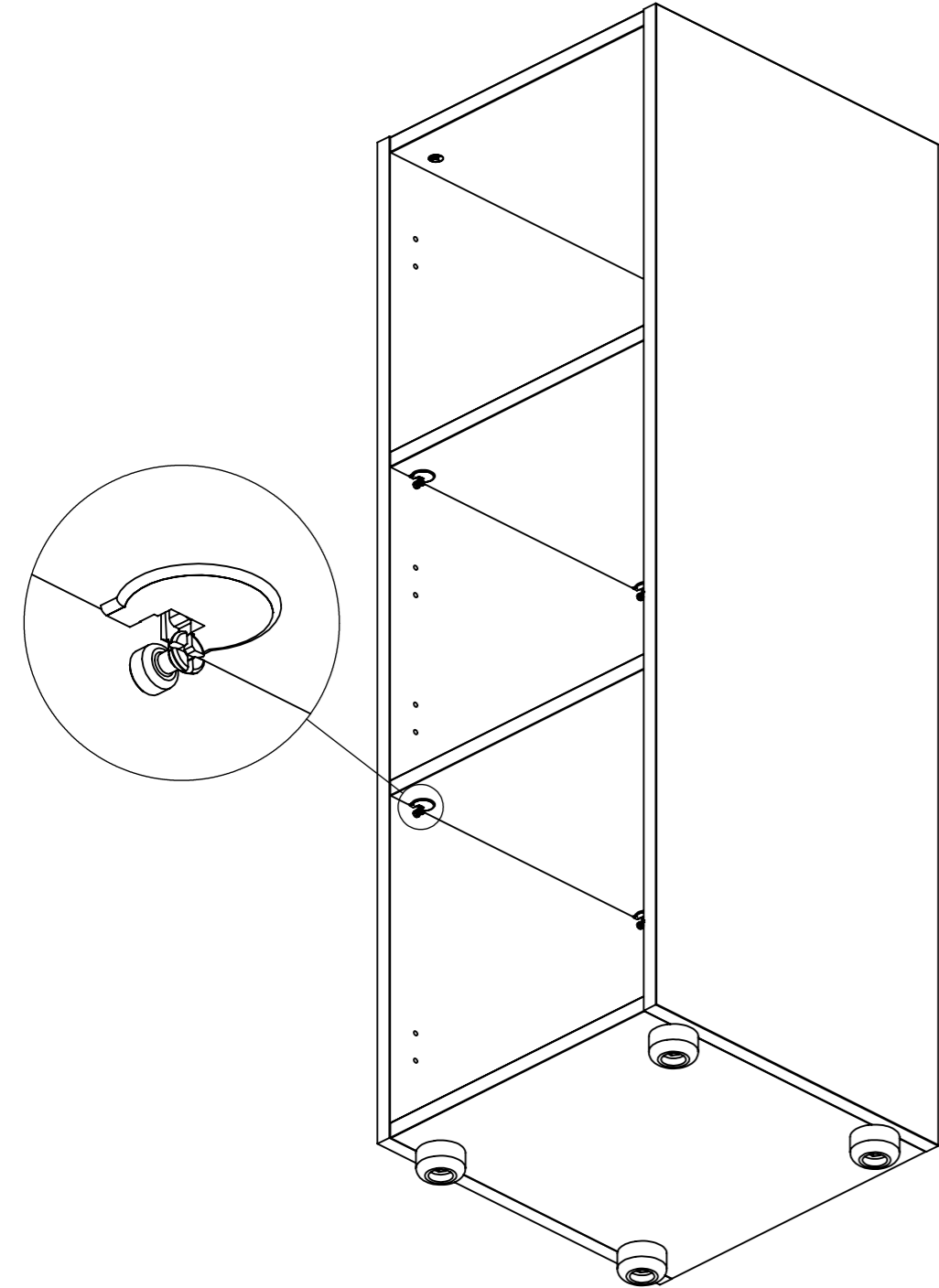
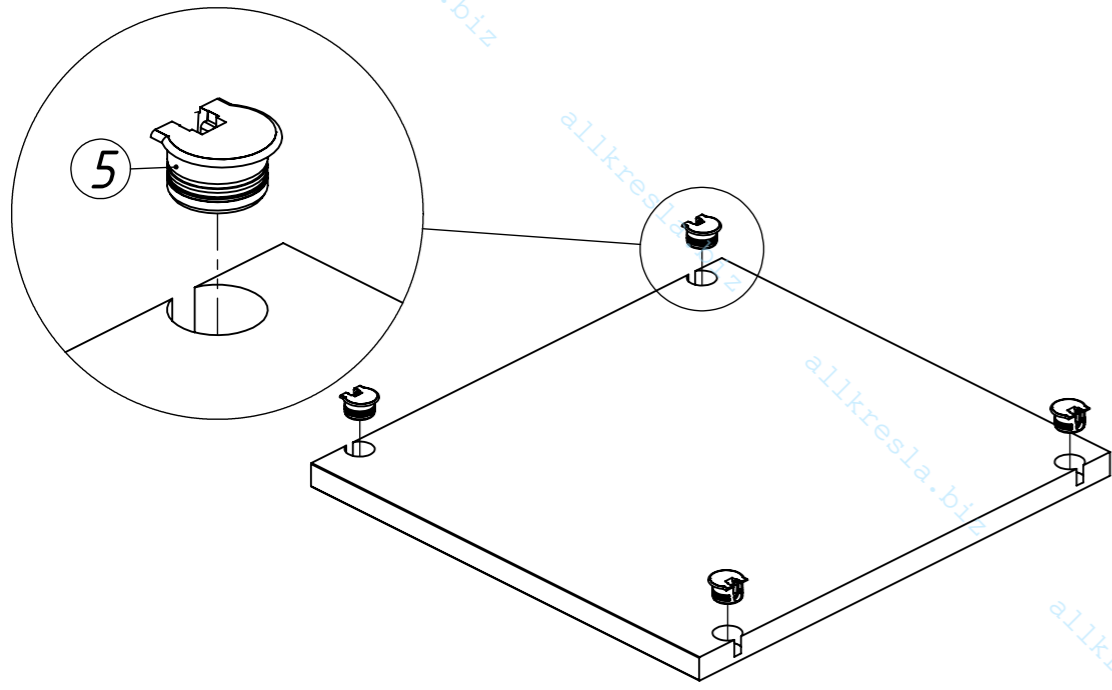

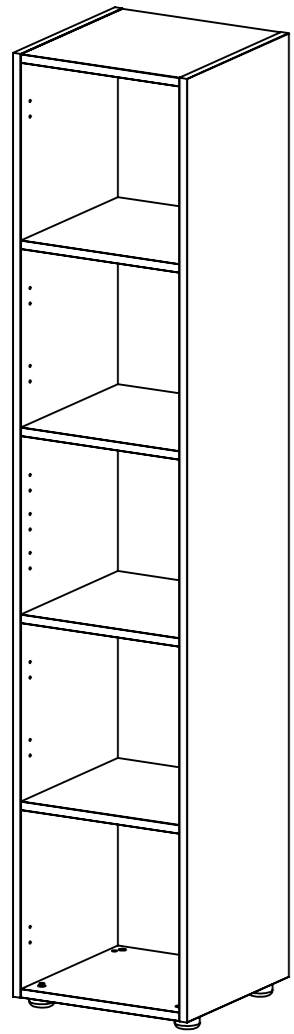

FHC 40

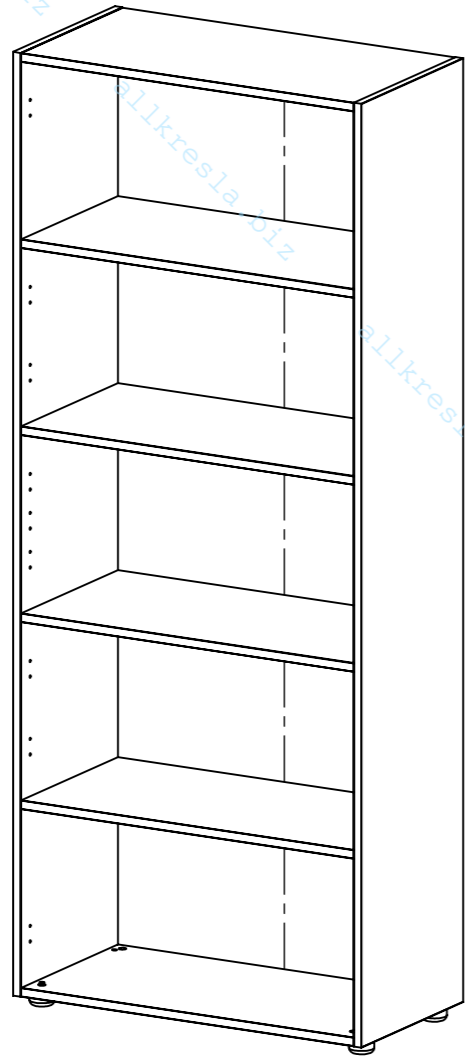

FHC 80

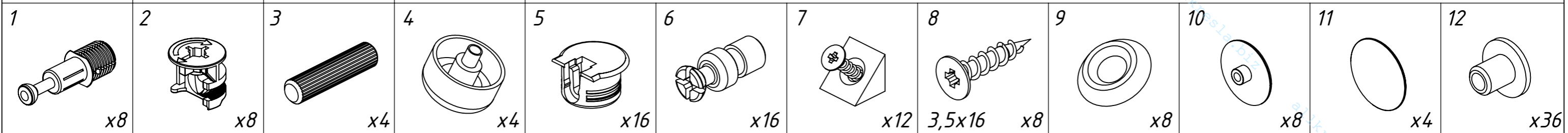
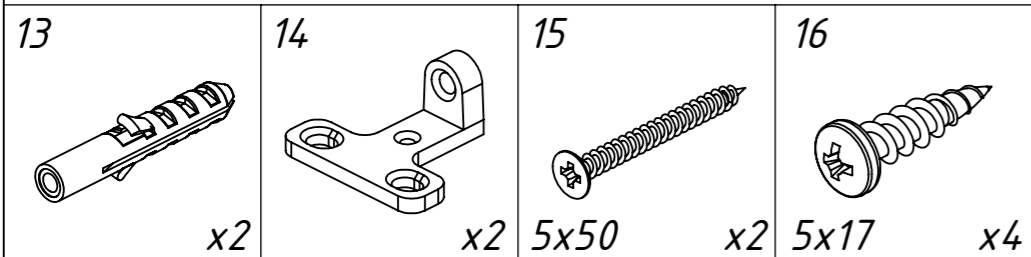
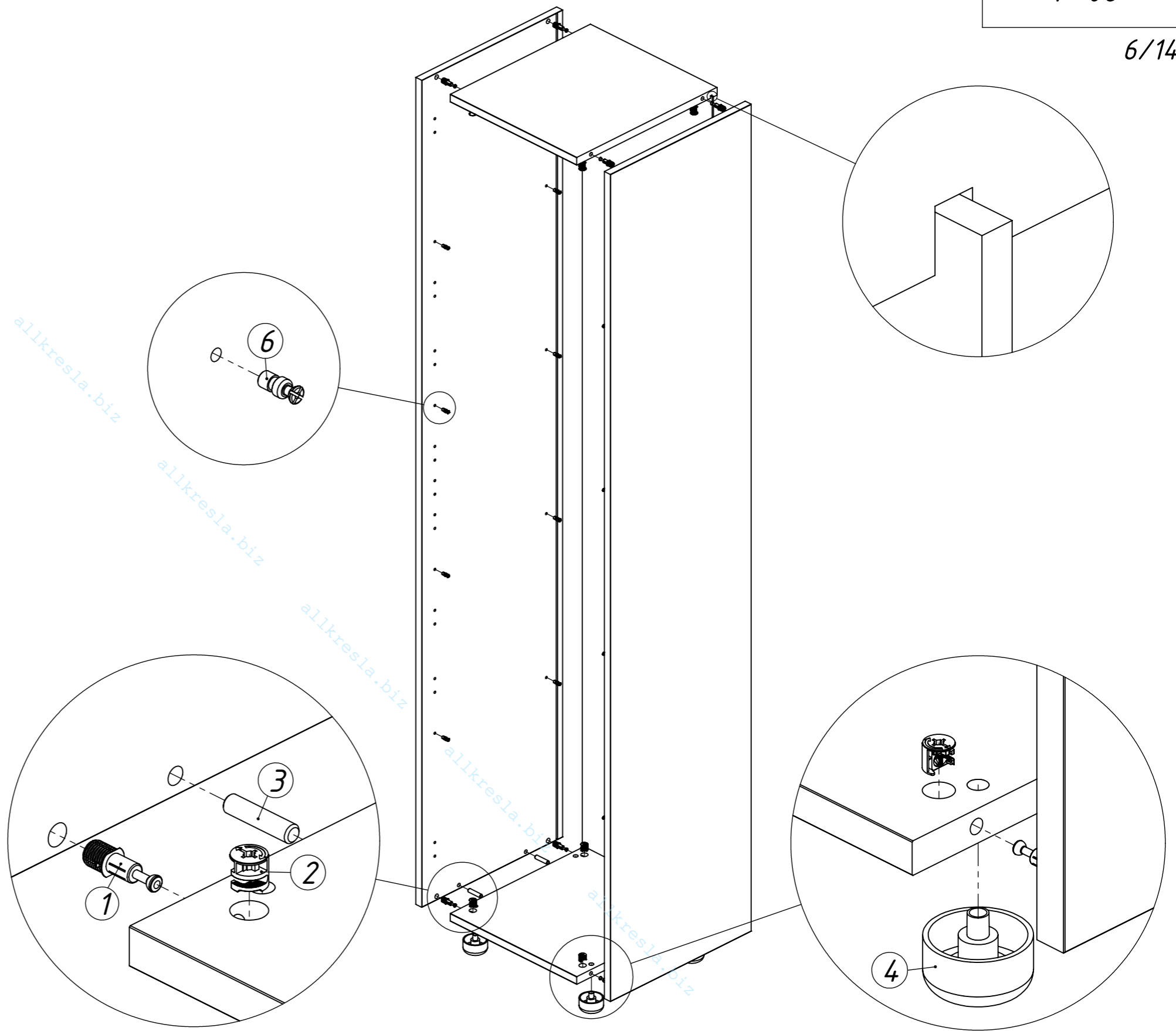

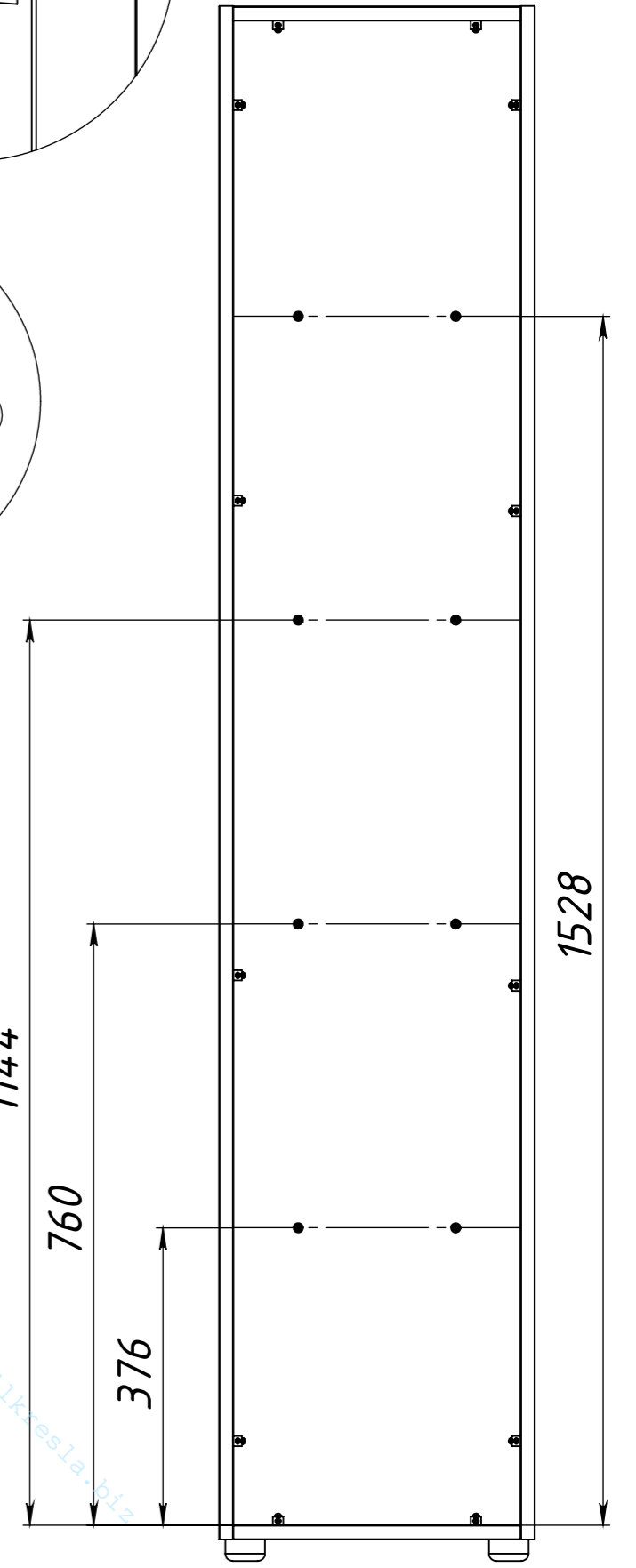
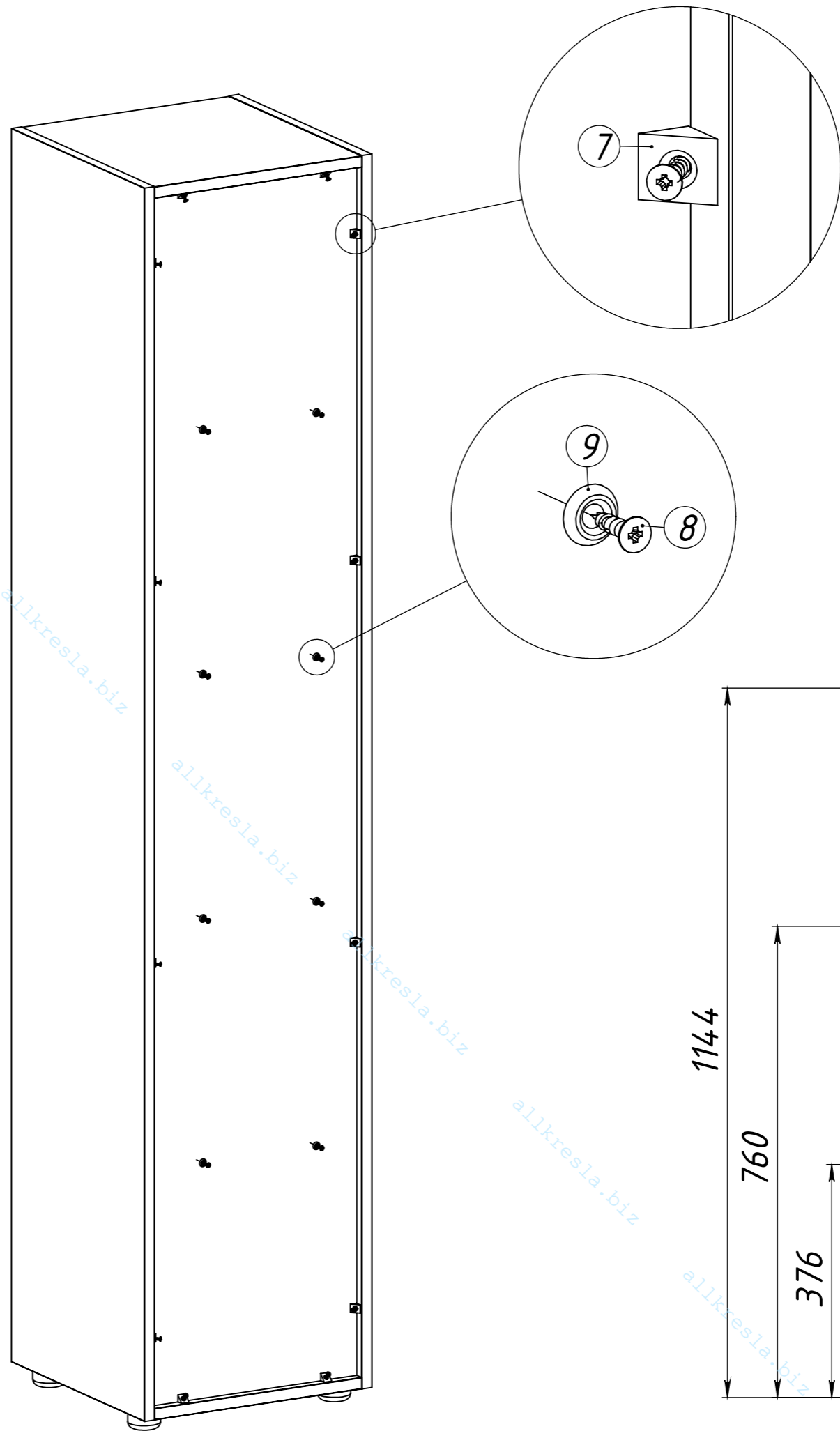
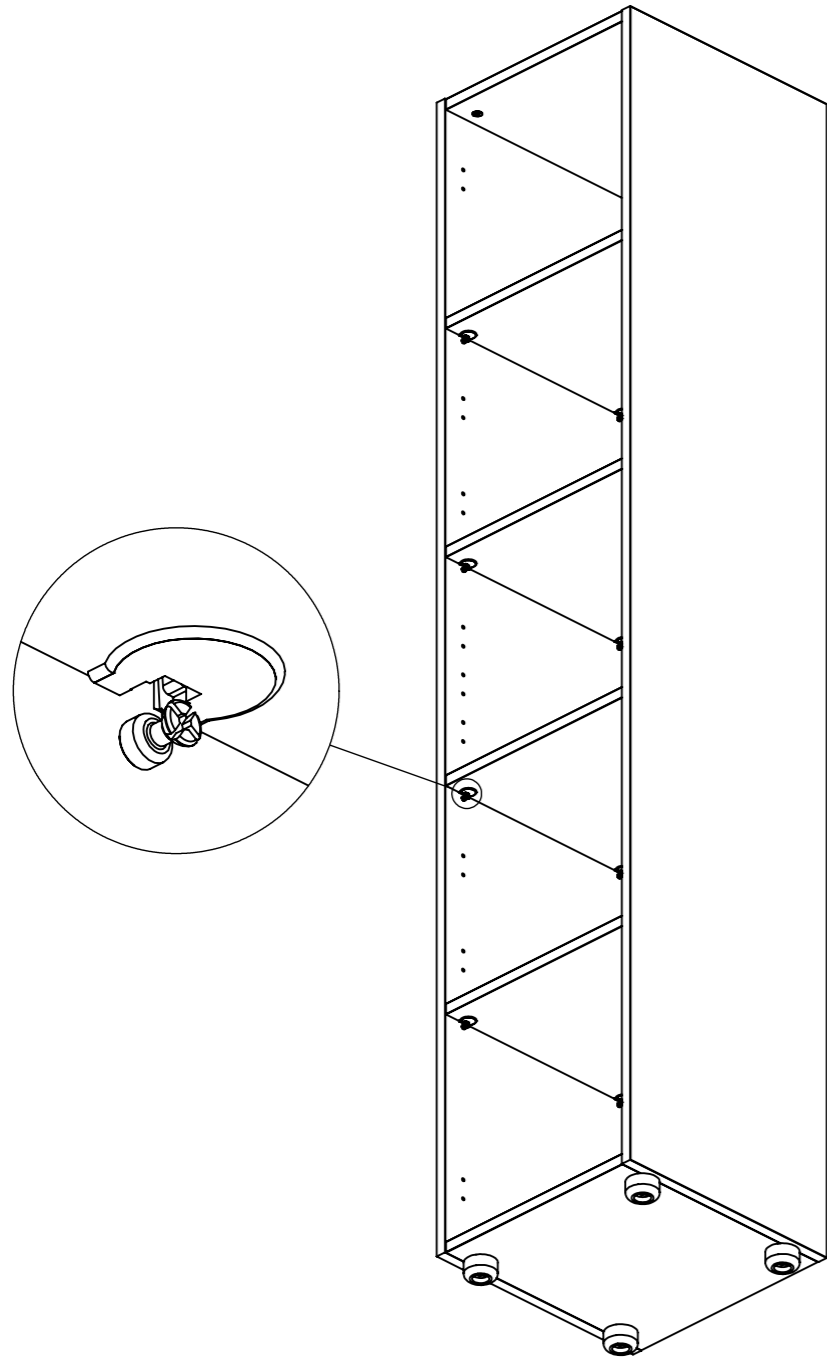
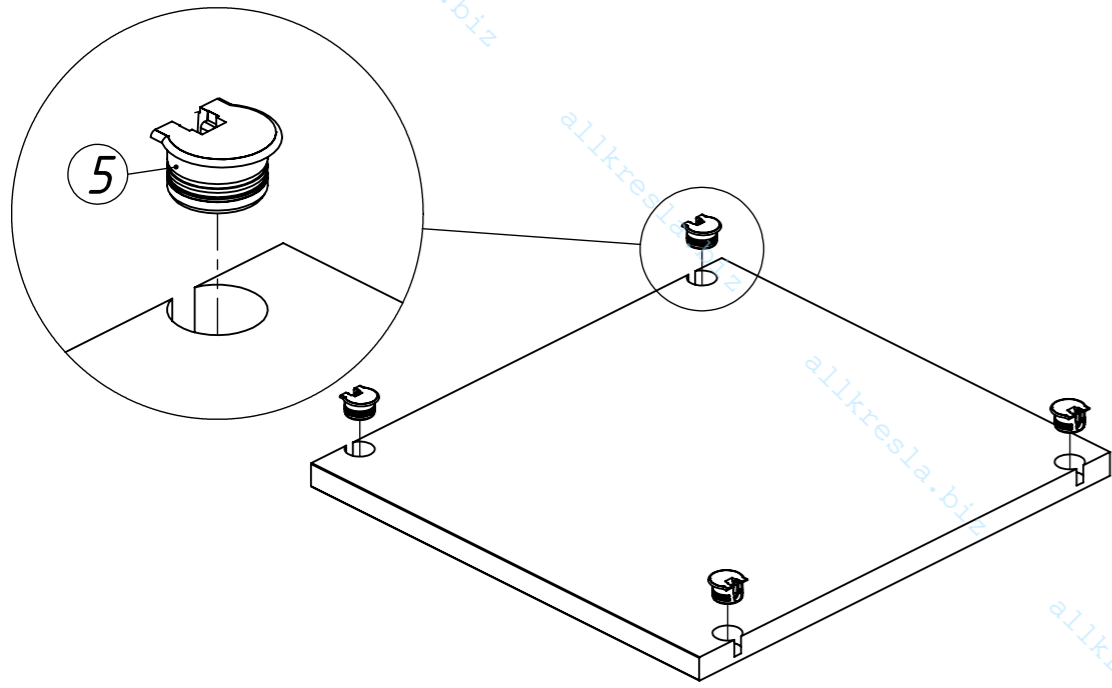

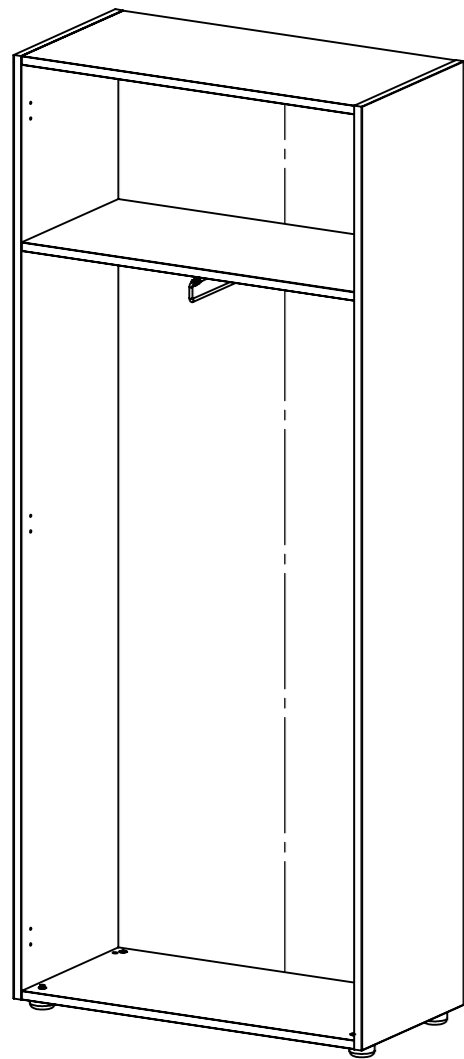

FCW 80-1

